

---

## KPM08A Specifications

|                                 |  |
|---------------------------------|--|
| <b>1. Rated Voltage</b>         | DC3.0V                                     |
| <b>2. Rated Current</b>         | <300mA                                     |
| <b>3. Inflation Time</b>        | <11 S (From 0 to 300 mmHg in a 50CC tank.) |
| <b>4. Air Flow Without Load</b> | >0.5LPM                                    |
| <b>5. Max. Pressure</b>         | >350mmHg                                   |
| <b>6. Leakage</b>               | Max. 3 mmHg/min from 300mmHg at 50CC tank. |
| <b>7. Noise Level</b>           | 65dB (30cm away)                           |
| <b>8. Apply For</b>             | Air  |

**PHYSICAL DIMENSION**

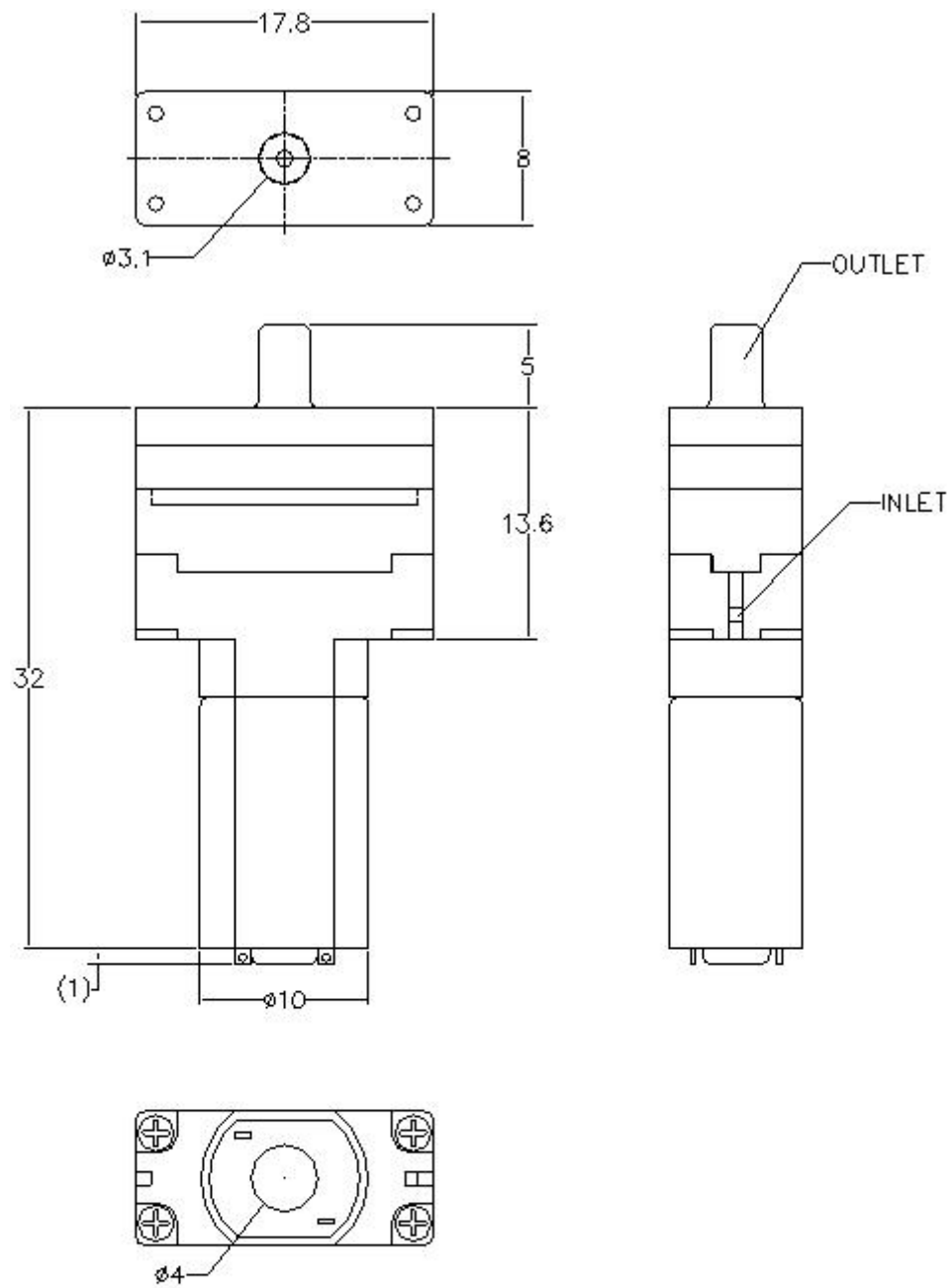

Unit:mm