

FGR37

主な用途/ATM
紙幣両替機
コインホッパー
ゲーム機器

Main Application/ Automated teller machine
Bill exchanger
Coin hopper
Game machine

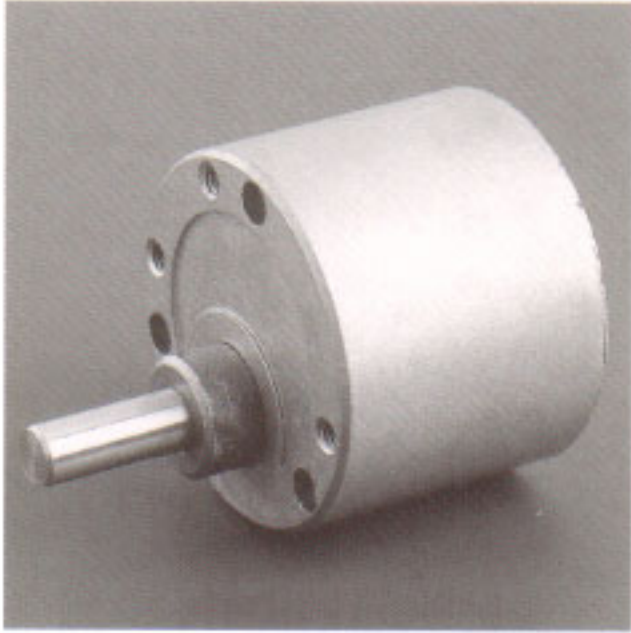

取付け可能なモーターモデル: FMR3138
FMR3526
FMR3650

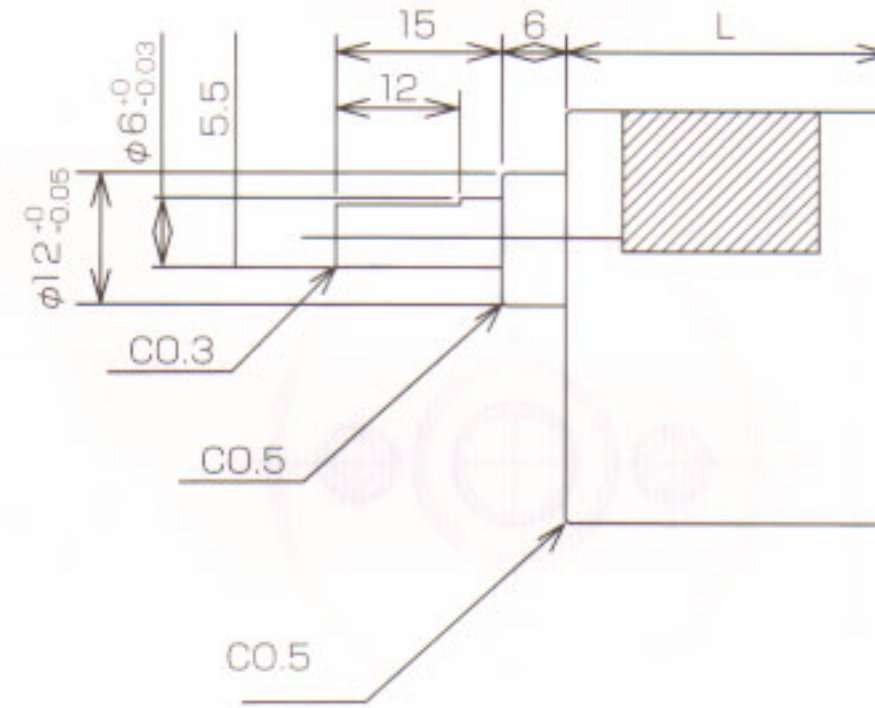
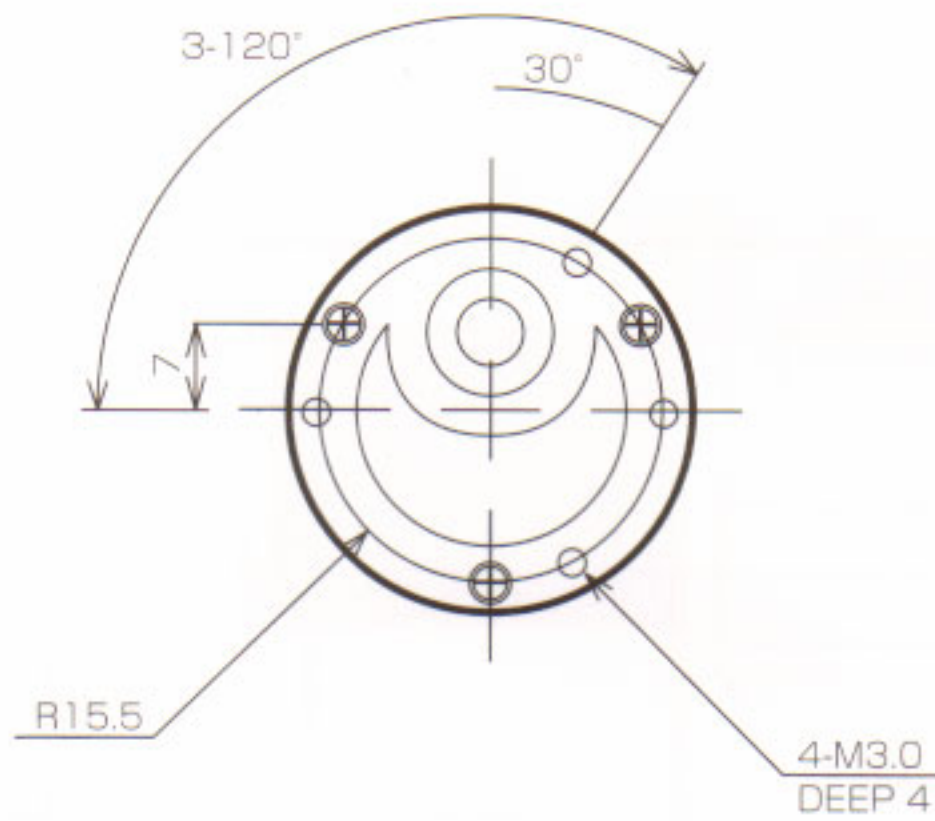

WEIGHT : 90g

GEAR BOXS SPECIFICATION (標準減速仕様)

Reduction ratio (減速比)	Rated tolerance torque (定格許容トルク)		Max momentary tolerance torque (瞬間最大許容トルク)		ℓ
	Kg · m	mN · m	Kg · m	mN · m	
1/10	1.0	98.0	3.0	294.0	24
1/25	↑	↑	↑	↑	↑
1/30	↑	↑	↑	↑	↑
1/50	6.0	588.0	18.0	1764.0	29
1/60	↑	↑	↑	↑	↑
1/75	↑	↑	↑	↑	↑
1/100	↑	↑	↑	↑	↑
1/120	↑	↑	↑	↑	↑
1/150	↑	↑	↑	↑	↑
1/200	↑	↑	↑	↑	↑
1/300	↑	↑	↑	↑	↑
1/500	↑	↑	↑	↑	↑
1/750	↑	↑	↑	↑	↑
1/900	↑	↑	↑	↑	↑