

FGR50

主な用途／コインホッパー
ゲーム機器
印刷機

Main Application／Coin hopper
Game machine
Printing machine

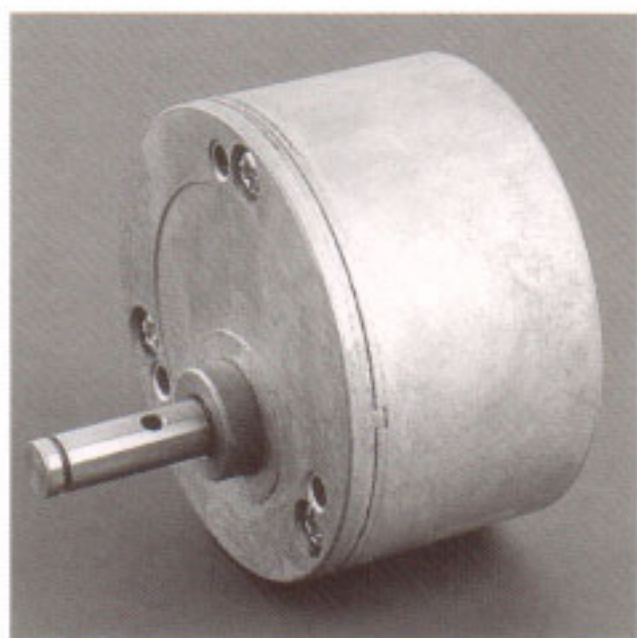

取付け可能なモーターモデル：FMR4545
FMR4560
FMR4570

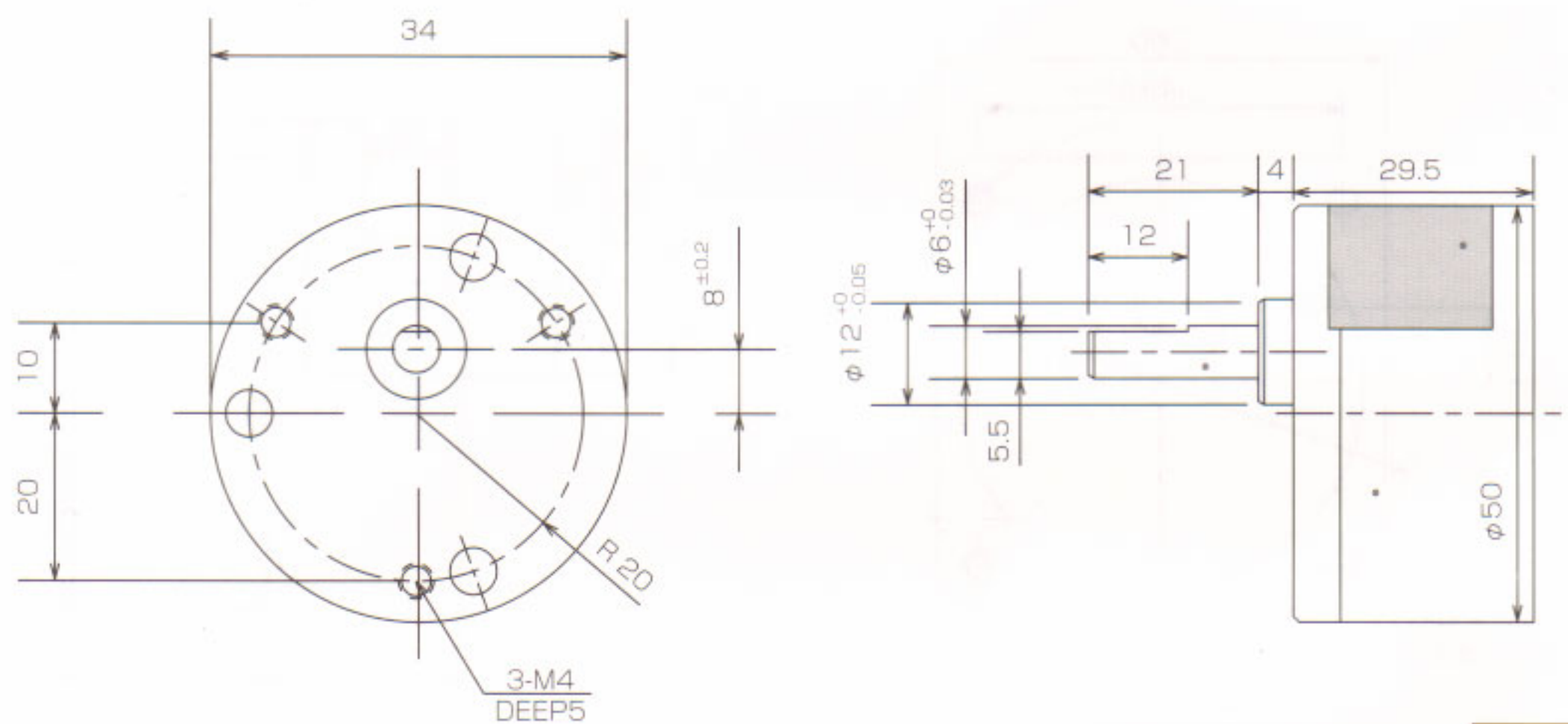

WEIGHT : 150g

GEAR BOX SPECIFICATION (標準減速仕様)

Raducation ration (減速比)	Rated tolerance torque (定格許容トルク)		Max momentary toleraance torgue (瞬間最大許容トルク)	
	Kg - m	mN · m	Kg - m	N · m
1/9	1.0	98.0	3.0	294.0
1/13	1.3	127.4	4.0	392.0
1/18	1.8	176.4	5.5	539.0
1/20	2.0	196.0	6.5	637.0
1/24	2.4	235.2	7.5	735.0
1/26	2.6	254.8	8.0	784.0
1/30	3.0	294.0	9.0	882.0
1/39	4.0	392.0	12.0	1176.0