

# FMF1426 FM-129

主な用途/電動工具  
オートカッター

Main Application/Electric tool  
Automatic cutter



MODEL	VOLTAGE		NO LOAD		AT MAXIMUM EFFICIENCY				STALL		
	OPERATING RANG	RATED	SPEED	CURRENT	TORQUE		SPEED	CURRENT	TORQUE		
			r/min	A	g-cm	mN-m	r/min	A	g-cm	mN-m	A
FMF1426 R1	10~30	24	19600	0.09	37	3.63	16300	0.43	220	21.6	2.1
FMF1426 R2	10~30	24	17800	0.06	31	3.04	15000	0.32	200	19.6	1.7

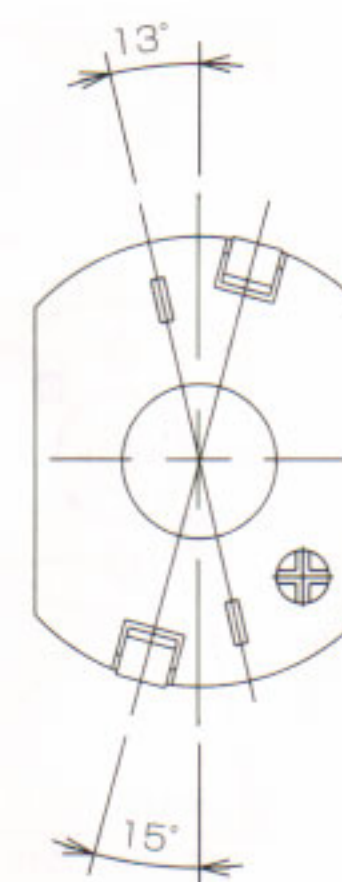
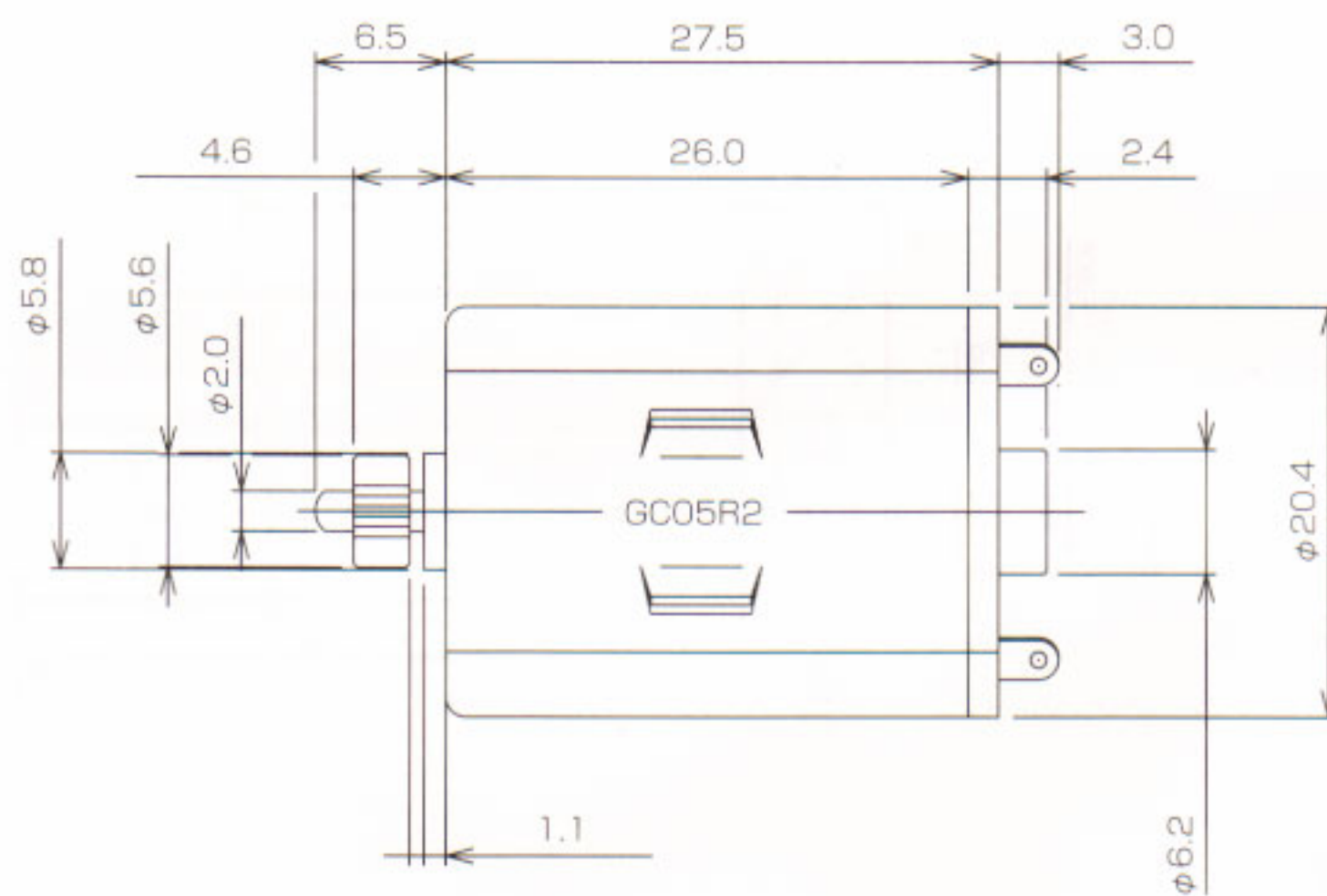
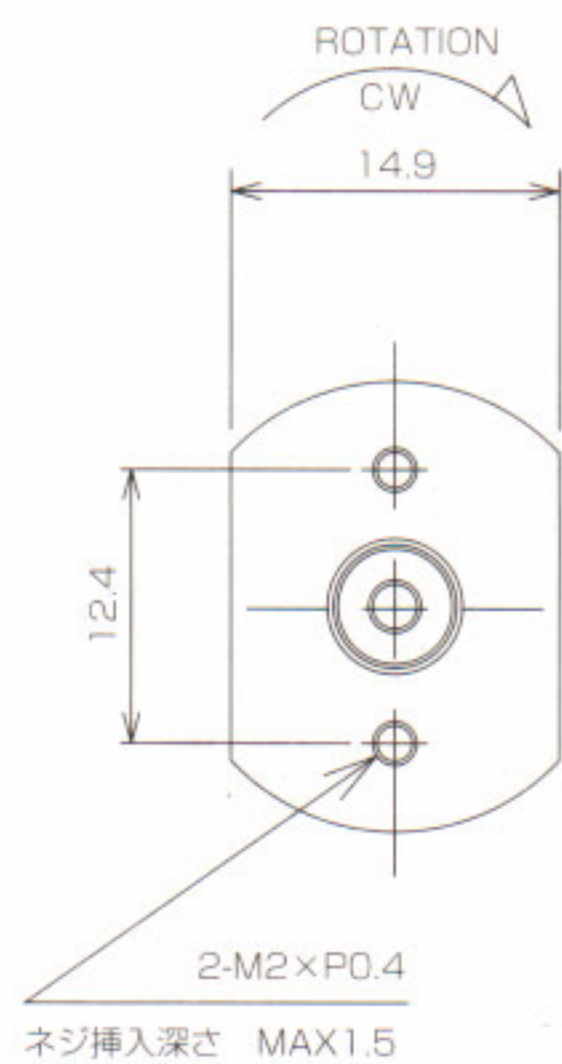

WEIGHT : 25g

## FMF1426 R1

24V

