

# FMF1531 FM-91

主な用途 / シェーバー  
バリカン  
プリンター

Main Application / Shaver  
Hair clipper  
Printing machine

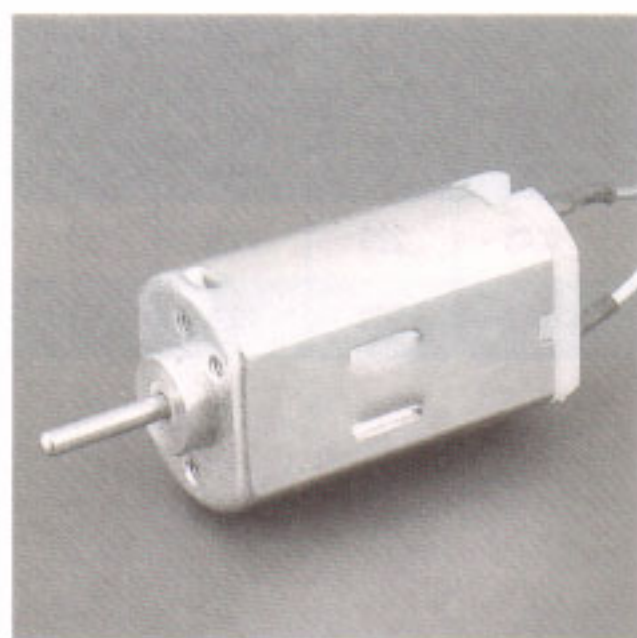

MODEL	VOLTAGE		NO LOAD		AT MAXIMUM EFFICIENCY				STALL		
	OPERATING RANG	RATED	SPEED	CURRENT	TORQUE		SPEED	CURRENT	TORQUE		
			r/min	A	g-cm	mN-m	r/min	A	g-cm	mN-m	A
FMF1531 S1	1~1.5	1.2	6700	0.285	14	1.37	5400	1.19	72	7.1	4.95
FMF1531 G1	1~3	2.4	9600	0.24	19	1.86	7900	1.1	107	10.5	5.10
FMF1531 J2S	1~3	2.4	10300	0.2	17	1.67	8600	1.0	103	10.1	5.05

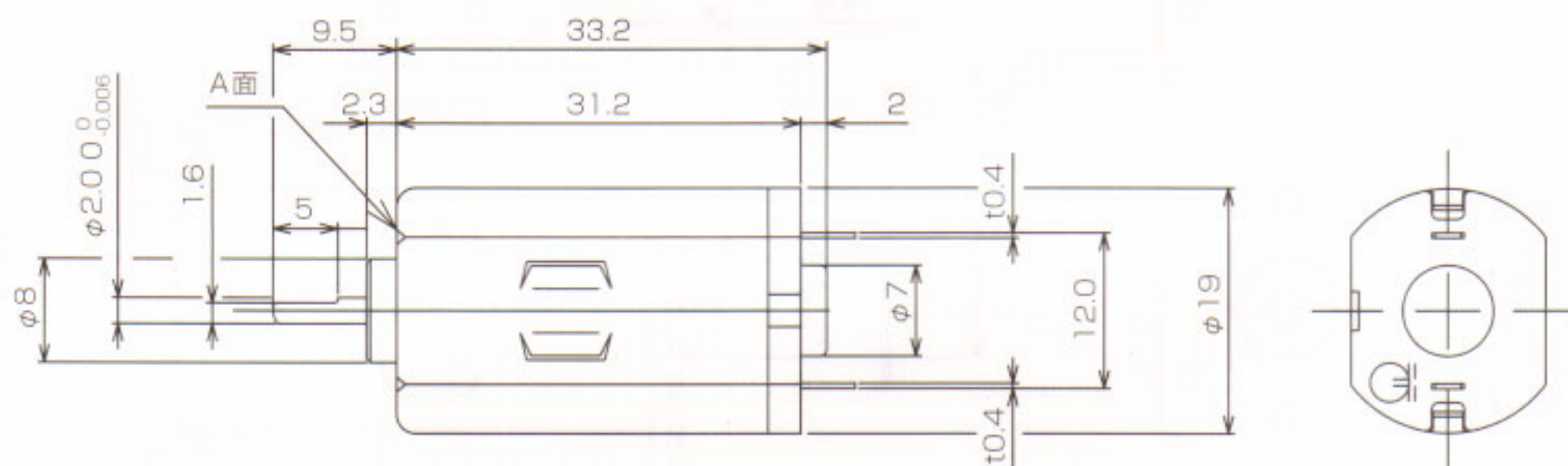
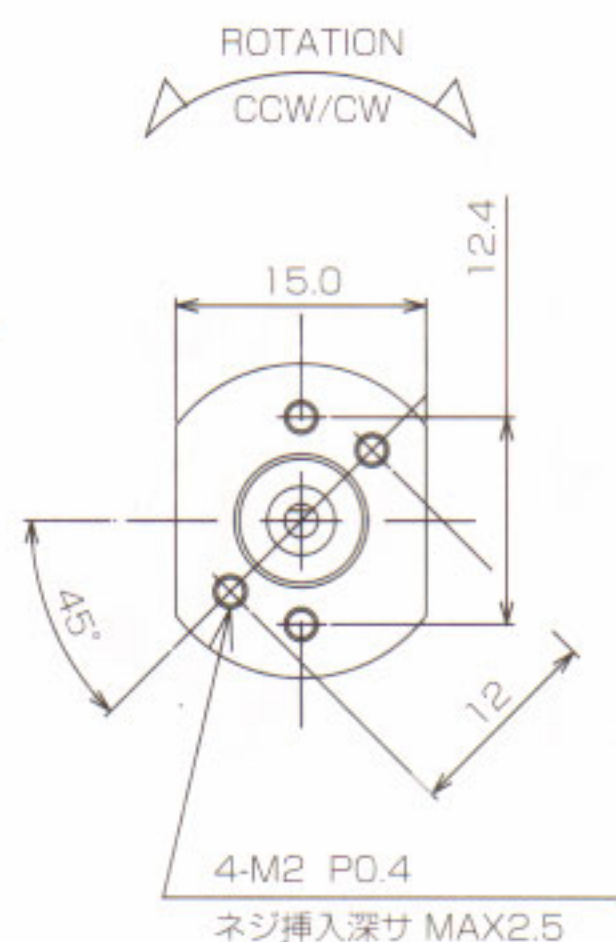

WEIGHT : 33g

## FMF1531 G1

2.4V

## FMF1531 S1

1.2V

