

FMF1832 FM-56

主な用途 / シェーバー

Main Application / Shaver



MODEL	VOLTAGE		NO LOAD		AT MAXIMUM EFFICIENCY				STALL		
	OPERATING RANG	RATED	SPEED	CURRENT	TORQUE		SPEED	CURRENT	TORQUE		
			r/min	A	g-cm	mN-m	r/min	A	g-cm	mN-m	A
FMF1832 A	1~1.5	1.2	7100	0.25	16	1.57	6000	1.36	103	10.1	7.42
FMF1832 J	1~3	2.4	8900	0.18	22	2.16	7600	1.07	153	15.0	6.36
FMF1832 JB1	1~3	2.4	9350	0.19	22	2.16	8000	1.13	155	15.2	6.78
FMF1832 JC1	1~3	2.4	9850	0.2	24	2.16	8500	1.28	175	17.2	8.22

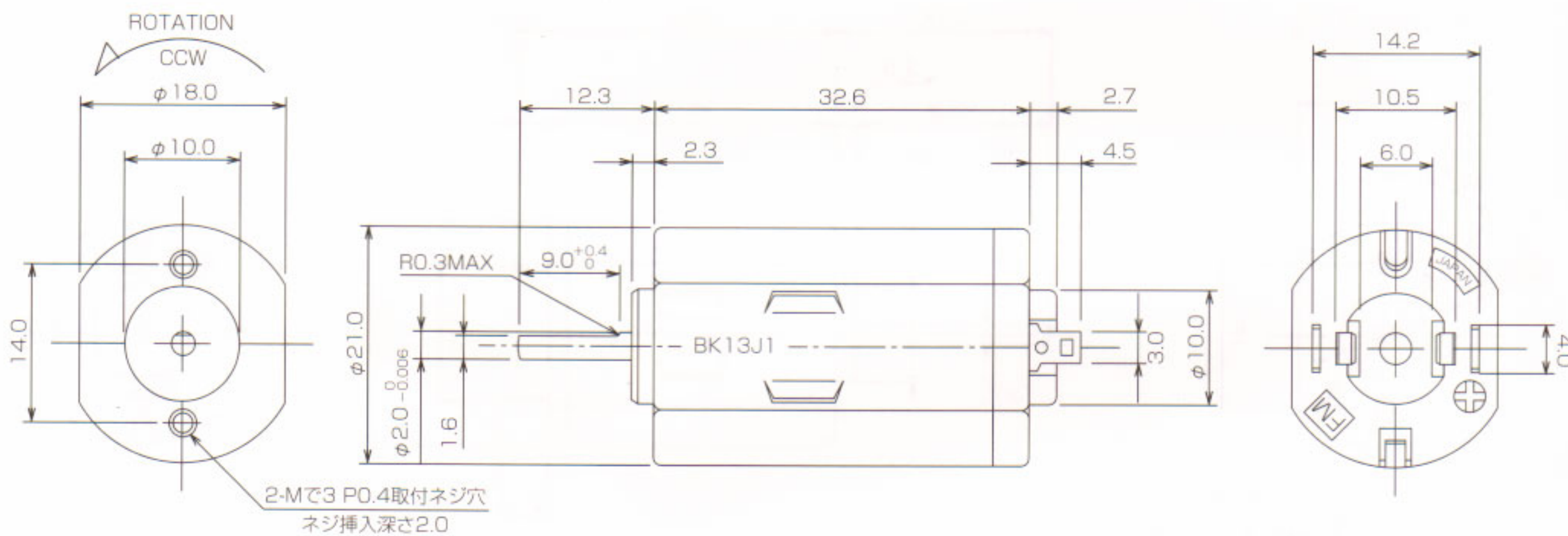

WEIGHT : 47g

FMF1832 A

2.4V

