

# FMF2965 FM-97

主な用途 / 掃除機パワーブラシ

Main Application / Vacuum cleaner power brush

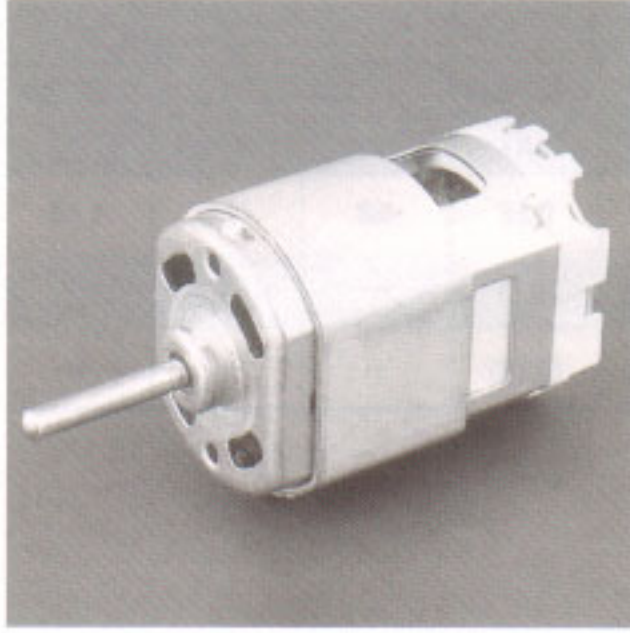

MODEL	VOLTAGE		NO LOAD		AT MAXIMUM EFFICIENCY				STALL		
	OPERATING RANG	RATED	SPEED r/min	CURRENT A	TORQUE		SPEED r/min	CURRENT A	TORQUE		CURRENT A
					g-cm	mN-m			g-cm	mN-m	A
FMF2965 12P1	80~120	100(AC)	12700	0.13	(150)	(14.7)	(10300)	(0.33)	—	—	—
FMF2965 12P1	100~240	200(AC)	13000	0.06	(150)	(14.7)	(10800)	(0.17)	—	—	—
FMF2965 L2	80~120	100(AC)	9800	0.12	(300)	(29.4)	(7600)	(0.44)	—	—	—

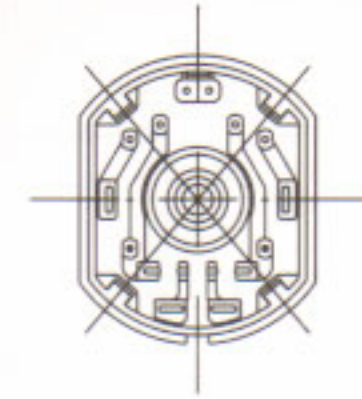
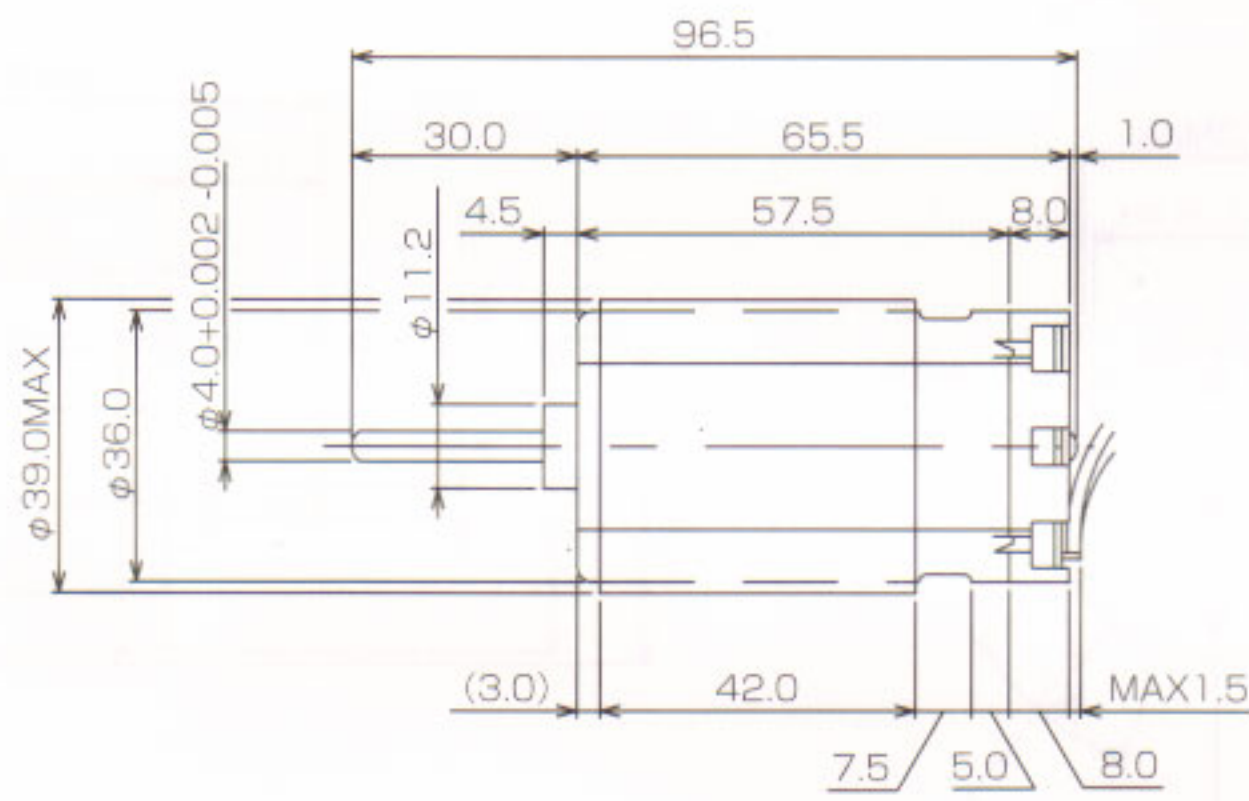
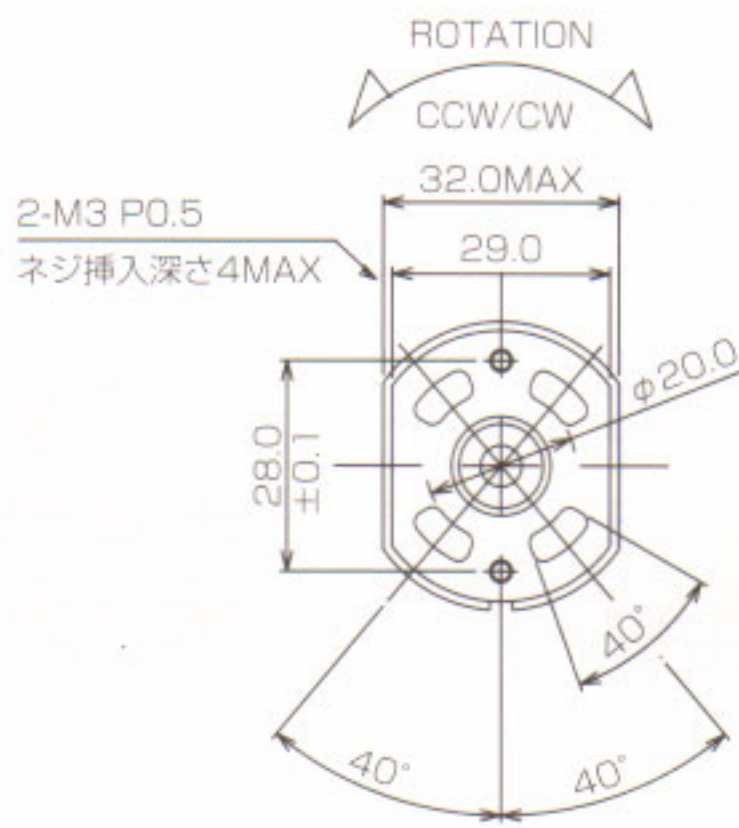

WEIGHT : 240g

## FMF2965 12P

100VAC

## FMF2965 12P12

220VAC

