

FMR2230 FM-51

主な用途 / エアコンダンパー
 マッサージャー
 監視カメラ
 ミニファックス
 計測器

Main Application / Auto air conditioner damper
 Massager
 Monitoring camera
 Mini fax
 Measurement apparatus

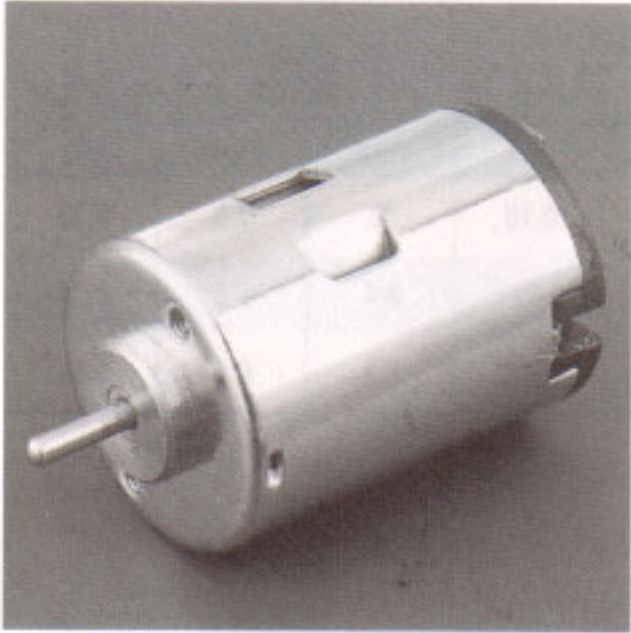

| MODEL | VOLTAGE | | NO LOAD | | AT MAXIMUM EFFICIENCY | | | | STALL | | |
|-------------|----------------|-------|----------------|--------------|------------------------|------|----------------|--------------|------------------------|------|------|
| | OPERATING RANG | RATED | SPEED r/min | CURRENT A | TORQUE g-cm mN-m | | SPEED r/min | CURRENT A | TORQUE g-cm mN-m | | |
| FMR2230 G | 1~1.5 | 1.2 | 7050 | 0.4 | 2.3 | 2.25 | 5800 | 1.85 | 129 | 12.7 | 8.58 |
| FMR2230 QG2 | 2~8 | 6 | 8700 | 0.09 | 21 | 2.06 | 7200 | 0.44 | 121 | 11.9 | 2.12 |
| FMR2230 QG1 | 6~15 | 12 | 8000 | 0.048 | 24 | 2.35 | 6500 | 0.22 | 128 | 12.5 | 0.97 |
| FMR2230 CC3 | 6~15 | 12 | 2800 | 0.013 | 8.5 | 0.83 | 1950 | 0.03 | 28 | 2.7 | 0.07 |
| FMR2230 QG | 10~30 | 24 | 8600 | 0.025 | 26 | 2.55 | 7150 | 0.12 | 154 | 15.1 | 0.59 |

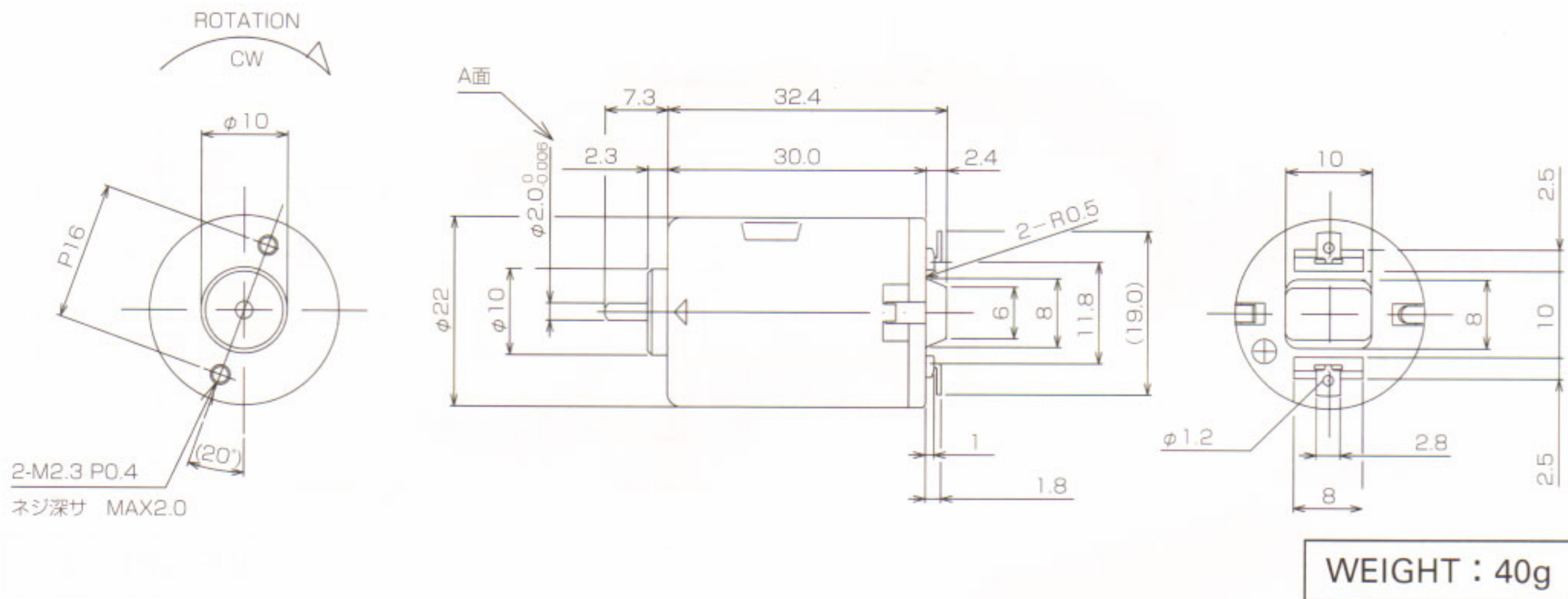

FMR2230 QG

24V

FMR2230 QG1

12V

