

FMR2531 FM-70

主な用途 / エアコンダンパー
血圧計
プリンター

Main Application / Air conditioner damper
Sphygmomanometer
Printing machine

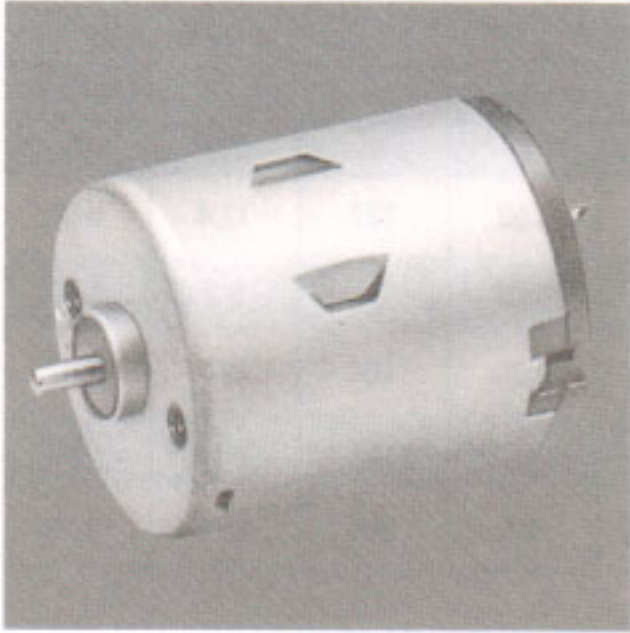

MODEL	VOLTAGE		NO LOAD		AT MAXIMUM EFFICIENCY				STALL		
	OPERATING RANG	RATED	SPEED r/min	CURRENT A	TORQUE		SPEED r/min	CURRENT A	TORQUE		CURRENT A
					g-cm	mN-m			g-cm	mN-m	A
FMR2531 QRB	2~8	6	4900	0.05	27	2.64	4200	0.28	196	19.2	1.74
FMR2531 QRE	2~8	6	3600	0.07	26	2.55	2800	0.25	120	11.8	0.91

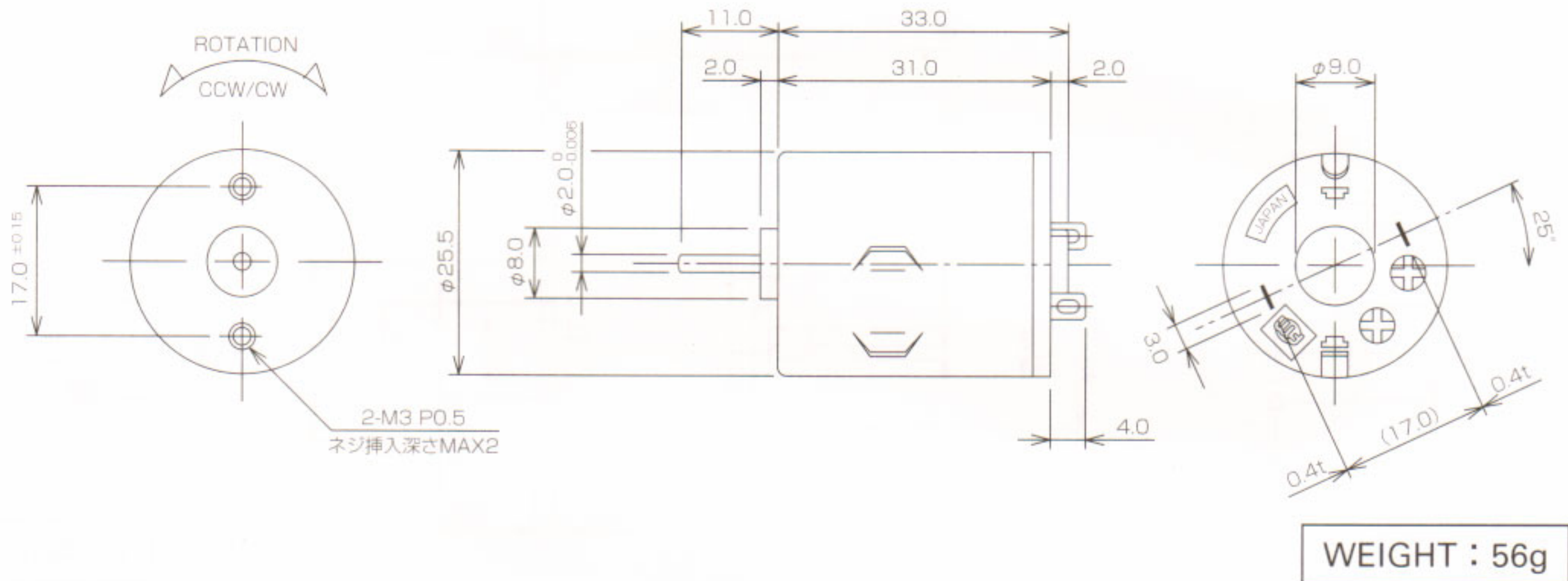

FMR2531 QRB

6V

FMR2531 QRE

6V

