

# FMR3522 FM-98

主な用途 / カーエアークリーナー  
ATM  
クリーナー

Main Application / Car air cleaner  
Automated teller machine  
Cleaner

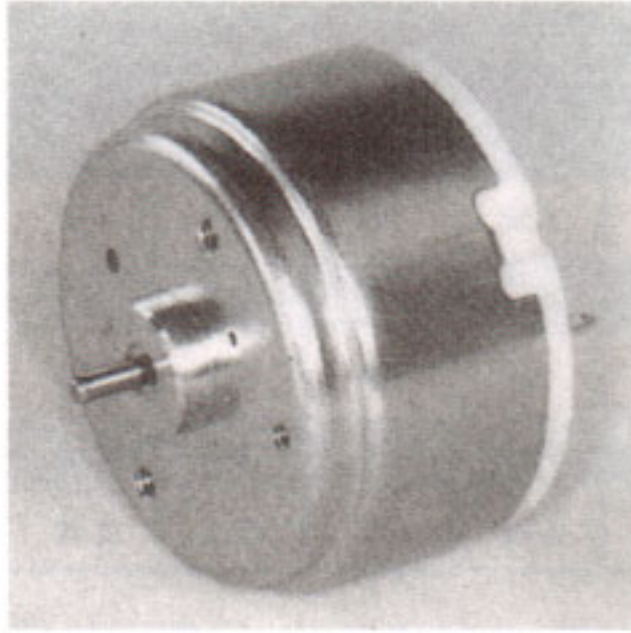

MODEL	VOLTAGE		NO LOAD		AT MAXIMUM EFFICIENCY				STALL		
	OPERATING RANG	RATED	SPEED	CURRENT	TORQUE		SPEED	CURRENT	TORQUE		
			r/min	A	g-cm	mN-m	r/min	A	g-cm	mN-m	A
FMF3522 LG1	6~15	12	3700	0.035	28	2.74	2800	0.11	115	11.3	0.34
FMF3522 LB24	10~30	24	4650	0.027	31	3.04	3600	0.09	137	13.4	0.31
FMF3522 Q	10~30	24	10000	0.045	30	2.94	8100	0.19	158	15.5	0.81

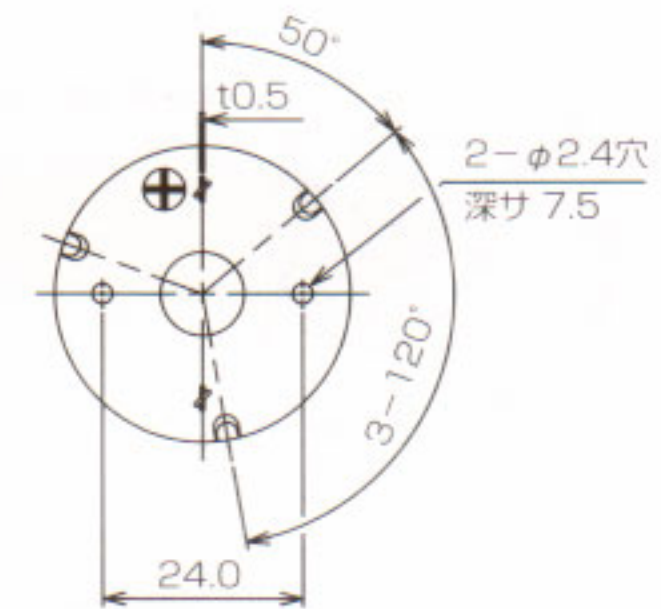
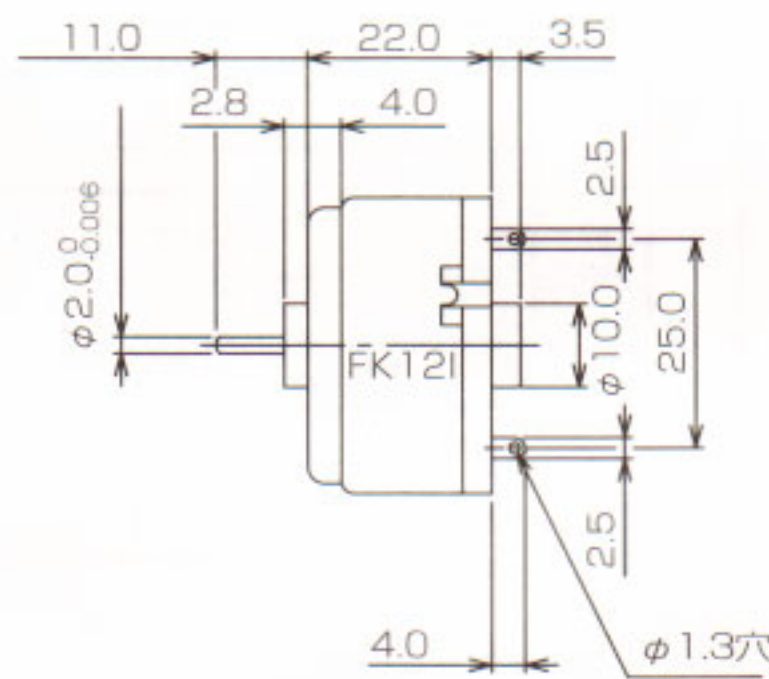
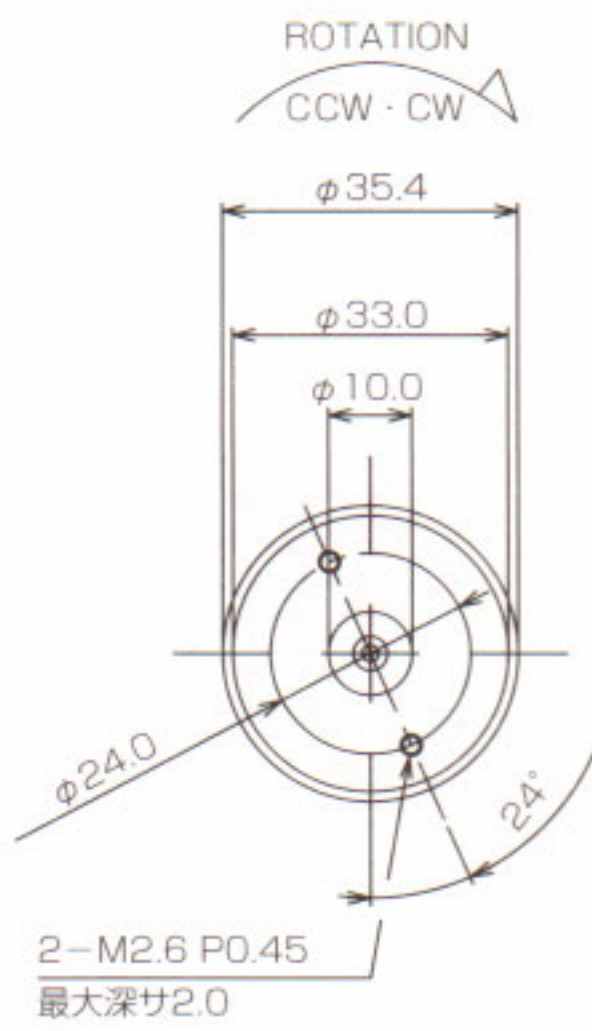

WEIGHT : 50g

## FMR3522 LG1

12V

## FMR3522 LB24

24V

