

# FMR3526 FM-32

主な用途 / ATM  
コピー機  
自動販売機

Main Application / Automated teller machine  
Copying machine  
Vending machine

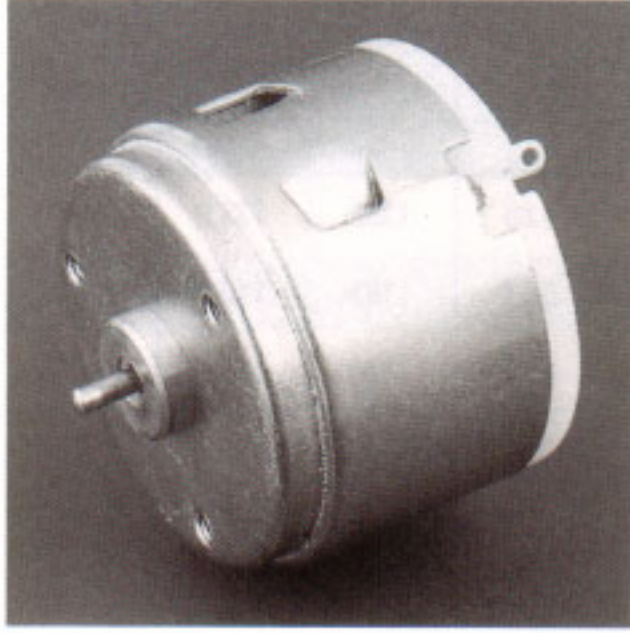

MODEL	VOLTAGE		NO LOAD *		AT MAXIMUM EFFICIENCY				STALL		
	OPERATING RANG	RATED	SPEED	CURRENT	TORQUE		SPEED	CURRENT	TORQUE		CURRENT
			r/min	A	g-cm	mN-m	r/min	A	g-cm	mN-m	A
FMR3526 QMA	2~8	6	4850	0.045	28	2.74	4200	0.30	209	20.5	1.95
FMR3526 QG1	10~30	24	5000	0.025	43	4.21	4150	0.12	253	24.9	0.59
FMR3526 QHA	10~30	24	6650	0.05	52	5.10	5350	0.21	266	26.1	0.87
FMR3526 QG7	10~30	24	7100	0.035	46	4.51	5900	0.18	272	26.7	0.89
FMR3526 QG	10~30	24	9800	0.055	53	5.19	8250	0.29	335	32.9	1.63

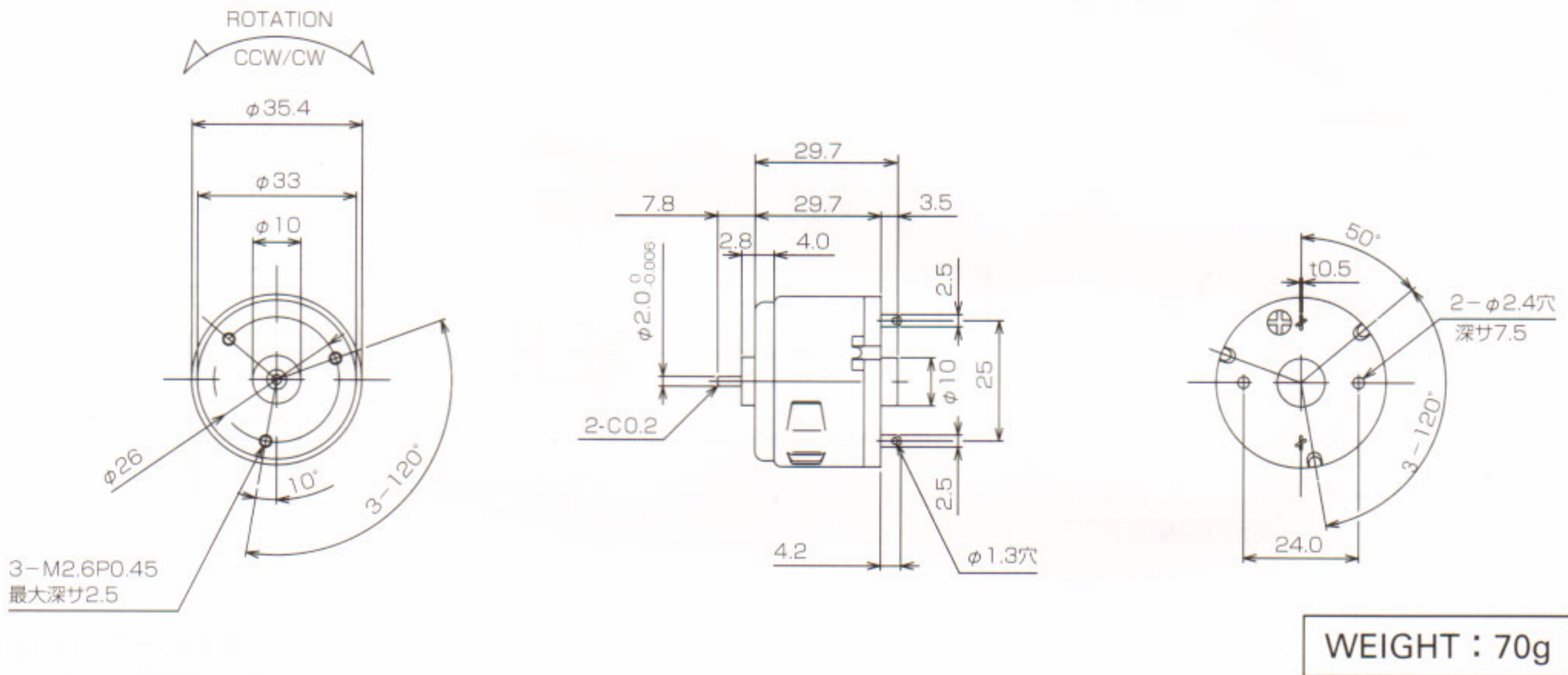

## FMR3526 QG

## FMR3526 QG1

