

FMR3640 FM-116

主な用途 / コインホッパー
電動工具
電動ホチキス
クリーナー

Main Application / Coin hopper
Electric tool
Electric stapler
Cleaner

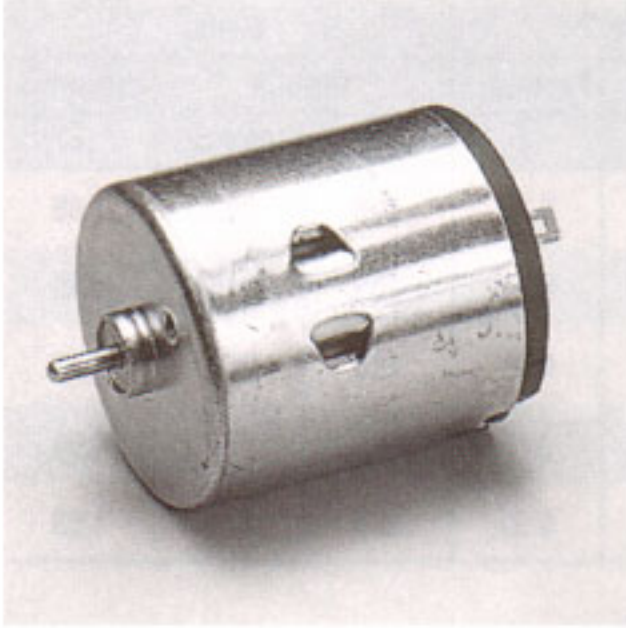

MODEL	VOLTAGE		NO LOAD		AT MAXIMUM EFFICIENCY				STALL		
	OPERATING RANG	RATED	SPEED r/min	CURRENT A	TORQUE g-cm mN-m		SPEED r/min	CURRENT A	TORQUE g-cm mN-m		CURRENT A
FMR3640 R1	10~30	24	9700	0.14	190	18.62	8350	0.86	1366	133.9	5.32
FMR3640 L1	10~30	24	6450	0.09	165	16.17	5550	0.57	1183	116.0	3.53
FMR3640 7PA	10~30	24	7900	0.11	225	22.05	6700	0.85	1490	146.1	5.01

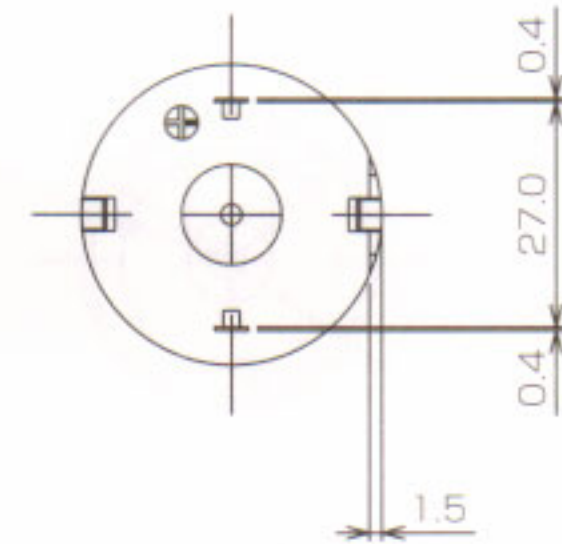
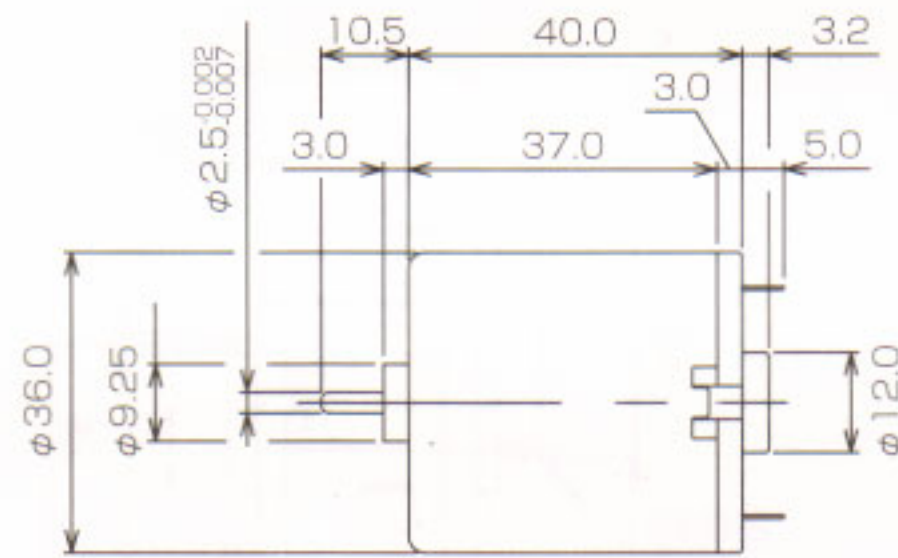
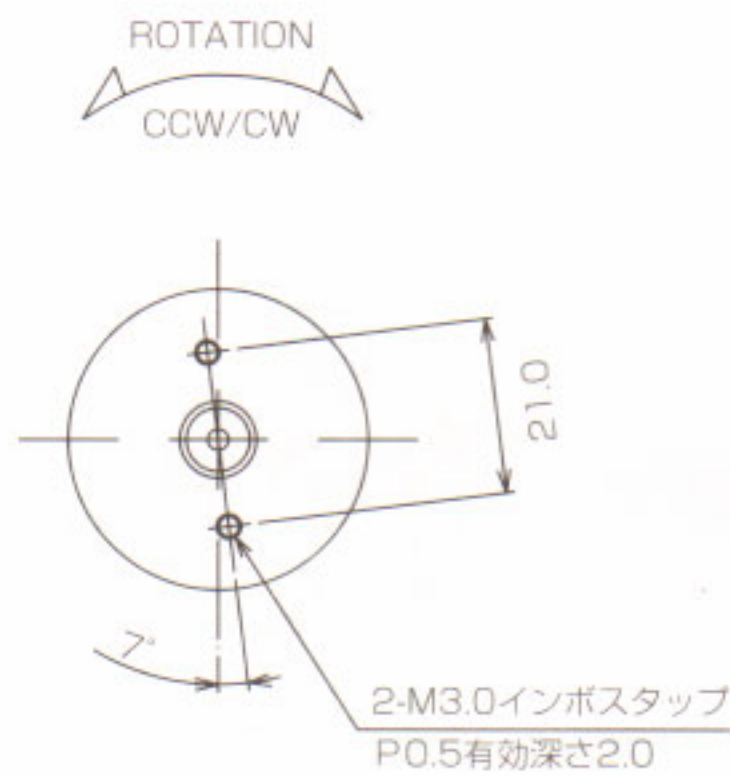

WEIGHT : 120g

FMR3640 7PA

24V

FMR3640 L1

24V

