

# FSR2515

主な用途 / エアコンルーバー  
ファックス  
スキャナー  
プリンター

Main Application / Air conditioner louver  
Fax  
Scanning machine  
Printing machine

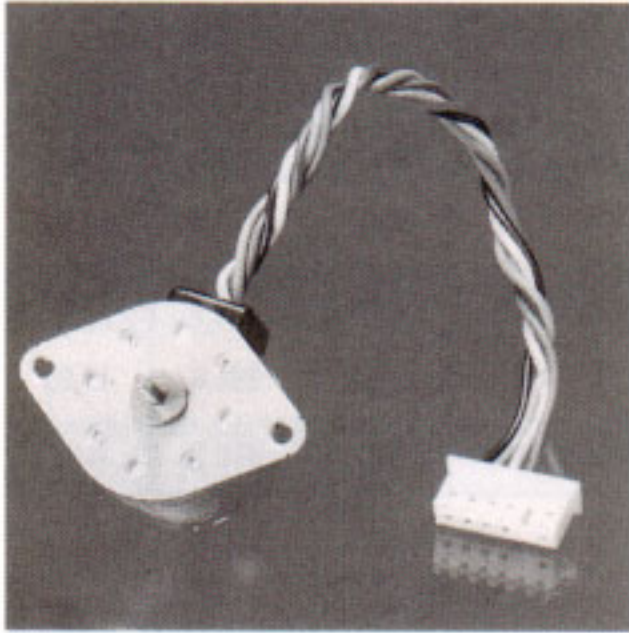

MODEL	STEP ANGLE	VOLTAGE	RESISTANCE	EXCITATION	PULL-IN TORQUE	PULL-OUT TORQUE	MAX PULL-OUT PULSE RATE	MAX PULL-IN PULSE RATE
FBR2525 1	7.5	12	75	unipolar(2-2)	35g-cm/250PPS	50g-cm/250PPS	800PPS	500PPS
FBR2525 2	7.5	12	50	unipolar(2-2)	55g-cm/250PPS	60g-cm/250PPS	900PPS	500PPS

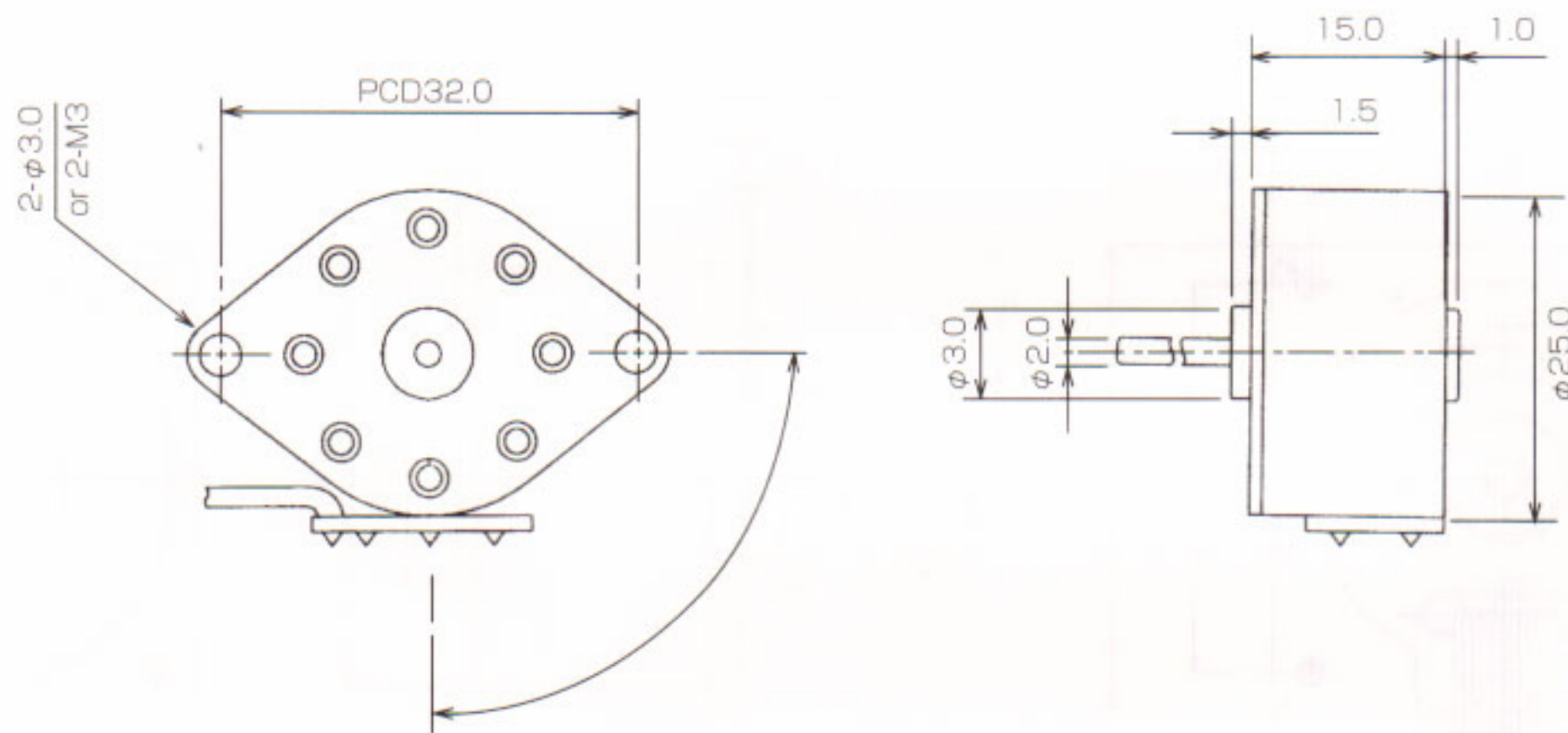

WEIGHT : 35g

## FSR2515 1

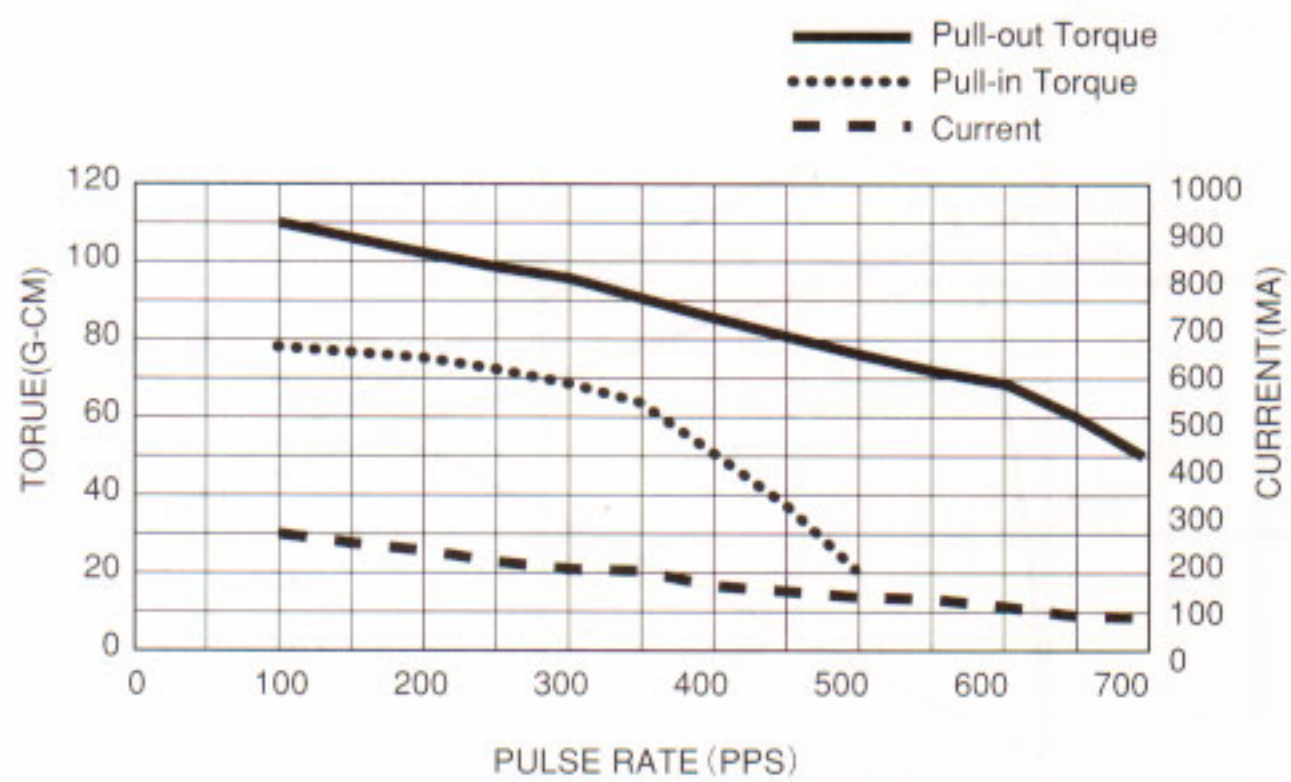

## FSR2515 2

