

# FSR3515

主な用途 / スキャナー  
 プリンター  
 ファックス  
 エアコンディショナー

Main Application / Scanning machine  
 Printing machine  
 Fax  
 Air conditioner

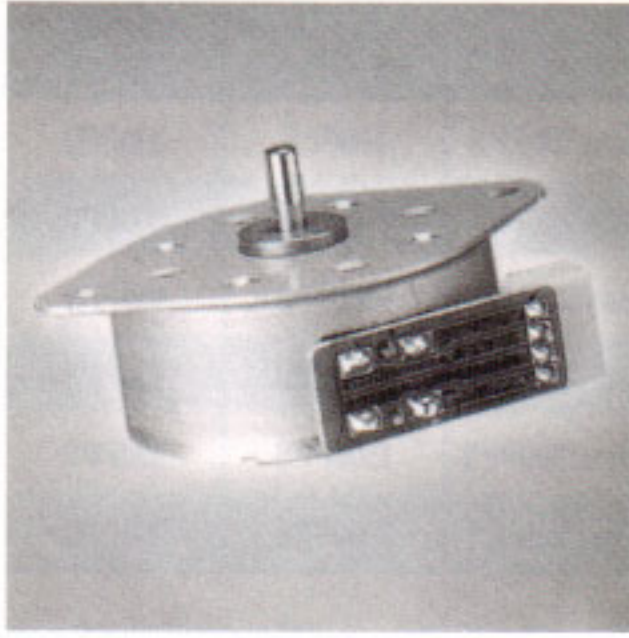

MODEL	STEP ANGLE	VOLTAGE	RESISTANCE	EXCITATION	PULL-IN TORQUE	PULL-OUT TORQUE	MAX PULL-OUT PULSE RATE	MAX PULL-IN PULSE RATE
FBR3515 1	7.5	12	50	unipolar(2-2)	80g-cm/200PPS	110g-cm/200PPS	600PPS	550PPS
FBR3515 2	7.5	5	17	unipolar(2-2)	10g-cm/350PPS	15g-cm/350PPS	360PPS	350PPS
FBR3515 3	3.75	12	20	unipolar(2-2)	60g-cm/100PPS	20g-cm/600PPS	1000PPS	450PPS
FBR3515 4	3.75	15	4	bipolar(2-2)	30g-cm/600PPS	120g-cm/600PPS	2200PPS	830PPS
FBR3515 5	3.75	12	10	bipolar(2-2)	75g-cm/100PPS	25g-cm/600PPS	1100PPS	600PPS

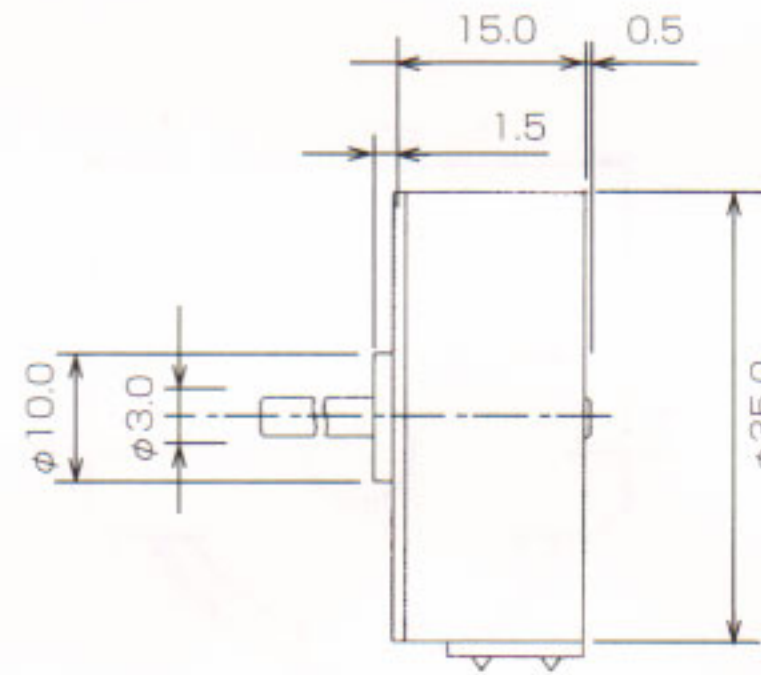
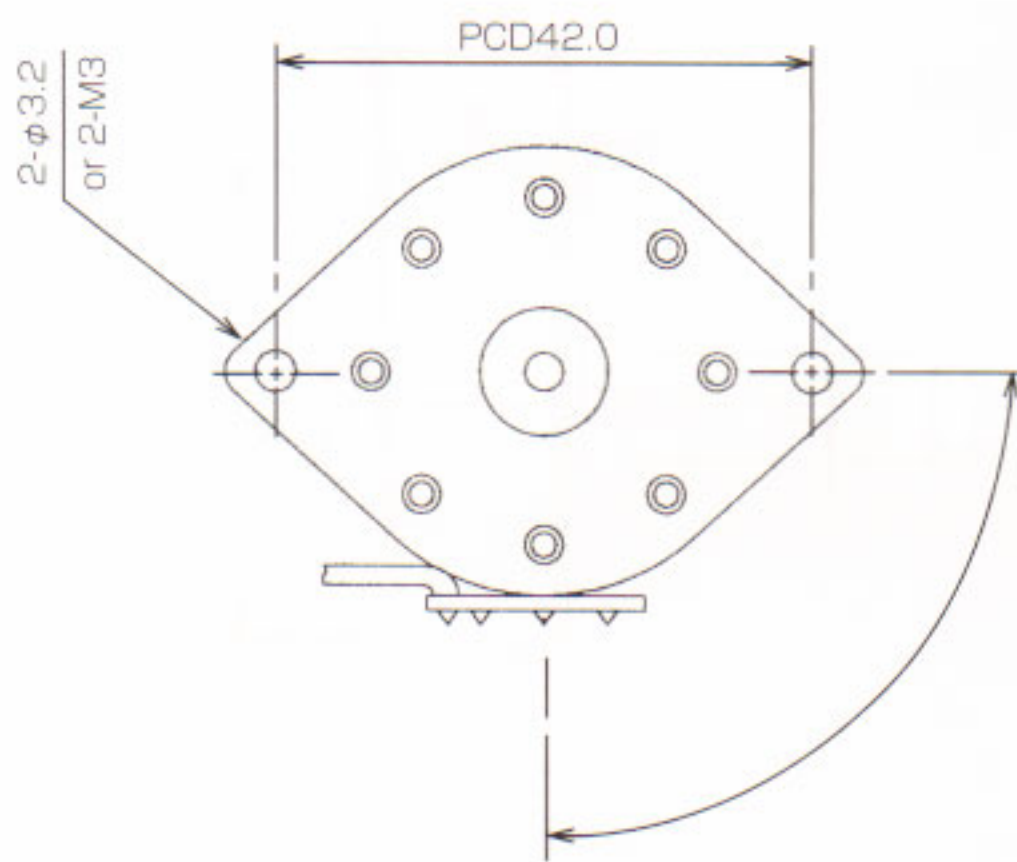

WEIGHT : 65g

## FSR3515 1

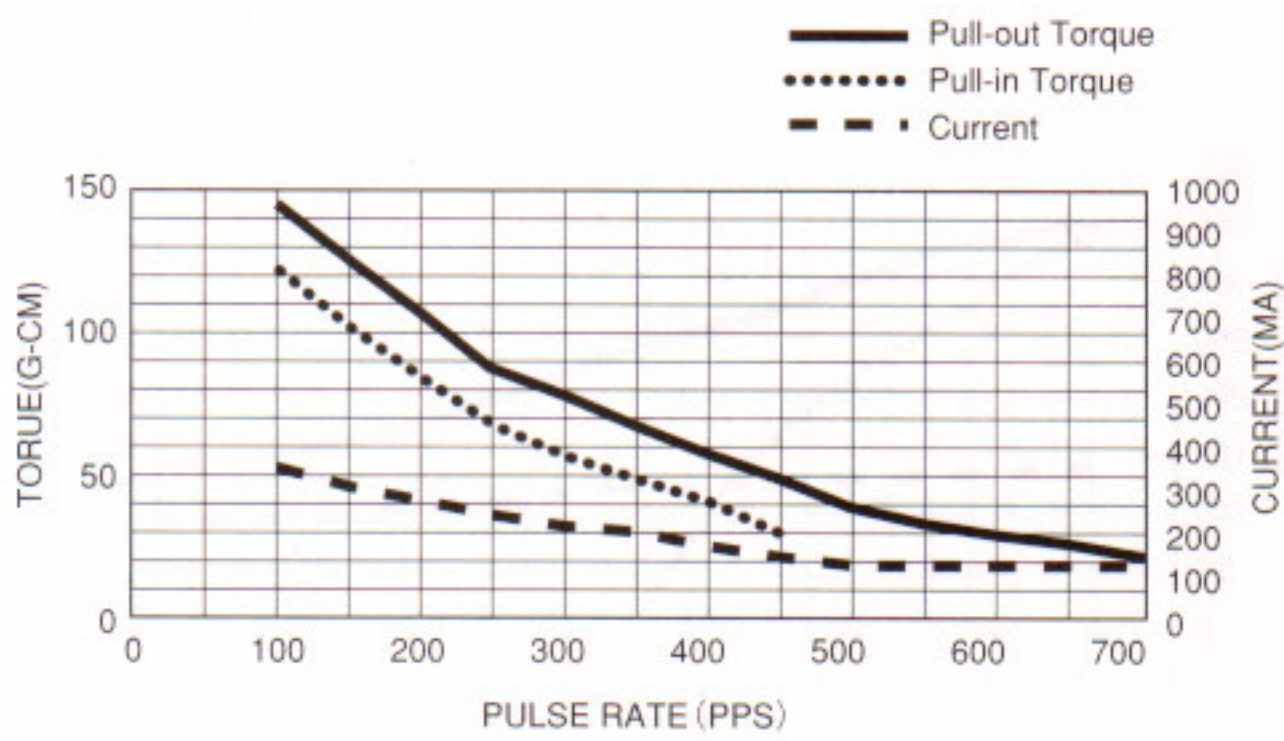

## FSR3515 5

